



Pretreatment and filterability tests of wastewater as a first step to characterize the influent to a membrane bioreactor

Beatriz Veces-Gadea^a, José-Antonio Mendoza-Roca^{a,*}, Amparo Bes-Piá^a,
Carlos Ferrer-Torregrosa^b, Francisco-Juan Martínez-Francisco^a

^a*Instituto de Seguridad Industrial, Radiofísica y Medio Ambiente, Universitat Politècnica de València, Camino de Vera s/n. 46022 Valencia, Spain*

Tel. +34 96 3877630; Fax: +34 96 3877639; email: jamendoz@iqn.upv.es

^b*Sociedad de Fomento Agrícola castellonense (FACSA), c/Mayor, 82-84. 12001 Valencia, Spain*

Received 30 May 2011; Accepted 4 September 2011

ABSTRACT

Wastewater reclamation and reuse has become one of the most important environmental issues nowadays. Thus, municipal wastewater treatment plants are being upgraded converting conventional activated sludge processes into membrane bioreactors in order to improve the quality of the treated wastewater. However, operational costs increase because of higher energy consumption and membrane fouling. Wastewater composition is one of the factors affecting membrane fouling, though its influence is difficult to describe. In this work, a study about wastewater pretreatment and filterability has been carried out in view of achieving valuable information for a further implementation of a membrane bioreactor. Experiments were performed with samples of four municipal wastewater treatment plants taken from the plant influent, the biological process influent and the plant effluent. Filterability was evaluated by membrane filtration resistances using the resistance in series model. Resistances were measured with ultrafiltration tests performed with flat membranes. Results showed that suspended solids concentration was the most influential parameter on the total membrane resistance when pretreated wastewater is filtered. No statistical correlation between the membrane resistances of biological process influent and plant effluent was found.

Keywords: MBR; Membranes; Resistances model; Municipal wastewater; Wastewater pretreatment; Ultrafiltration

1. Introduction

Wastewater reclamation and reuse has become one of the most important environmental issues nowadays. Increasing of population growth together with water scarcity has led to enhance the efficiency of wastewater reclamation and reuse processes. In this way membrane bioreactors (MBR) are being implemented in

municipal wastewater treatment plants as an appropriate alternative to produce a final effluent that could be applied for irrigation.

MBR is a combination of biological degradation by activated sludge and direct solid-liquid separation by membrane filtration. Many advantages are provided using ultrafiltration or microfiltration instead of the secondary clarifier [1]. Thus, it can be highlighted that the plant footprint is reduced and the quality of the final effluent is higher than that from a conventional activated

*Corresponding author.

sludge process. In this way, the ability of the system to disinfect produces a free pathogenic microorganisms effluent. Besides, further advantages like reduction of sludge production are also reported [2,3].

Nevertheless, capital cost for the membranes system itself and operating costs of membrane cleaning should be taken into account, as well as membrane fouling, what is considered the principal disadvantage of membrane bioreactors for the treatment of wastewater. Fouling leads to a decrease in permeability and consequently to the increase of the chemical cleanings. The main fouling mechanisms are reported in the literature [4–7].

The parameters influencing membrane fouling can be divided into four groups: membrane module design, operation of the membrane filtration, biological treatment characteristics and membrane material [8,9]. Within the biological treatment group, sludge properties, formation/accumulation of problematic substances, wastewater composition and pretreatment have to be considered.

In the literature a great number of papers relating membrane fouling with sludge properties including extracellular polymeric substances can be found in the last decade [10–13]. However, the influences of the pretreatment and especially of the wastewater composition on the membrane fouling have been hardly studied.

Concerning the wastewater pretreatment, it has to be commented that when MBR technology was introduced in Europe, first wastewater treatment plants went in operation performing a conventional mechanical treatment without any special pre-treatment unit. Braids were observed after operation hanging between the membranes. Thus, sieves have to be used as a mechanical pre-treatment. Frechen et al. [14,15] described the fundamentals of sieving as a mechanical pre-treatment in MBR plants and a comparison among different types of sieves was made. Authors reported that it is necessary to draw the attention not only to gap sizes but also to gap geometries and number of stages in the pre-treatment units. Removal efficiencies are function of all of them. Schier et al. (2009) summarized the efficiency of mechanical pre-treatment on European MBR plants [16].

Van der Roest et al. (2002) compared the performances of various MBR plants, also comparing at the same time the pretreatments with different kinds of sieves [17]. Rusten and Odegaard (2006) realized a comparative study among pretreatments of conventional plants whose results could be equally used for MBR plants [18]. They reported about the quality of the effluents both from sieves and from primary clarifiers. They stated that clarifiers as a pre-treatment do not achieve the required EU removal efficiencies. Thus, sieve units in the range of 250–500 microns will be the proper choice.

However, it is very difficult to evaluate the influence of the wastewater characteristics entering the MBR, i.e., after the pretreatment, on the MBR performance. This is due to the multiple factors affecting the membrane fouling and to the changes experimented by the organic matter in the degradation reactions.

In this paper, apart from the comparison of different pretreatments, a first approach to study the influence of the wastewater composition on the ultrafiltration process has been carried out for municipal wastewater. For that, samples from 4 different municipal wastewater treatment plants were characterized and ultrafiltration tests were performed both with samples coming from the influent and from the effluent of the biological treatment. The measurement of the filterability of both types of samples could be the first step to study the influence of the wastewater composition of the final UF stage in a MBR process.

2. Methodology

2.1. Wastewater samples

Samples were collected from 4 municipal wastewater treatment plants (MWWTPs) whose biological treatment consisted in activated sludge processes operated as extended aeration. The design flow rates and the characteristics of their pretreatments are summarized in Table 1. The four WWTPs are located in the province of Castellón in the Valencian region in Spain.

Sampling was performed in three points: plant influent (PI), influent to the biological process (BPI) and effluent from the plant (PE). The influent to the biological process coincides with the pretreatment effluent, since there is not primary settling, and the plant effluent coincides with the effluent from the biological process. Samples were always taken at the same time (4 P.M.).

Table 1
Design flow rates and characteristics of the pretreatments of the studied MWWTP

	WWTP 1	WWTP 2	WWTP 3	WWTP 4
Design flow rate (m ³ /d)	1704	13500	9000	9000
Coarse bar screen	40 mm	50 mm	150 mm	50 mm
Fine bar screen	NO	NO	NO	YES
Sieve	2 mm	3 mm	3 mm	NO
Sand removal/ Degreasing	YES Aerated	YES Aerated	YES Aerated	YES Aerated
Equalization tank	NO	YES	YES	YES

For the pretreatment study 5 PI samples from each MWWTP were taken. For the filterability experiments 2 BPI and 2 PE samples were processed.

2.2. Analysis

Suspended solids were measured in triplicate for each sample. Cellulose acetate membrane filters (0.45 μm , 47 mm of diameter) from LABSCIENCE were used. The analysis was carried out according APHA (2005). Oil and greases, which were measured gravimetrically, and total solids (TS) were also determined according APHA [19].

2.3. Study of the pretreatment

With the PI samples, a pretreatment study was carried out using three mesh stainless steel sieves from FILTER-LAB. The mesh sizes were 150, 500 and 900 μm and suspended solids were quantified after sieving the different samples. The volume of sample used was 1 l.

2.4. UF laboratory plant

Experiments for membrane resistances determination of the different wastewater samples (BPI and PE) were performed with an UF flat-sheet membrane module. The UF module was RAYFLOW X100 from TECHSEP. The tested membranes were from MICRO-DYN-NADIR (150,000 Da of MWCO) and were provided by ECOTEC. The membrane active surface was 100 cm^2 . Fig. 1 shows a scheme of the laboratory plant used for the experiments.

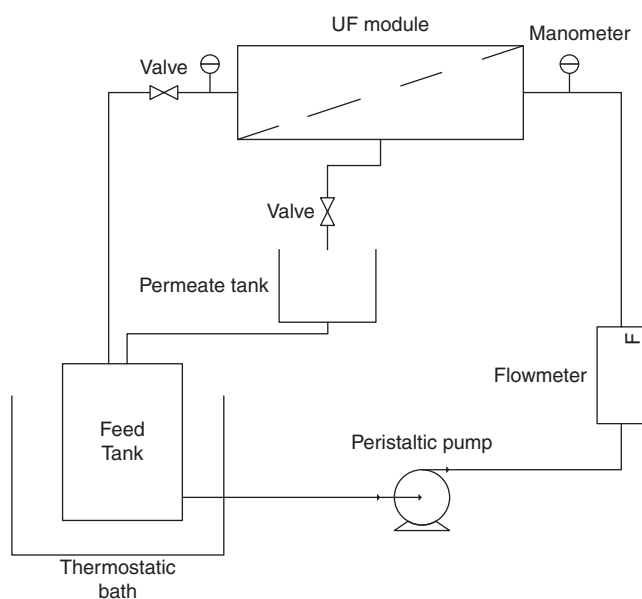

Fig. 1. Scheme of the UF laboratory plant.

Temperature was maintained at 27°C by the thermostatic bath and transmembrane pressure was set at 0.3 bar by adjusting the valve located at the retentate side of the membrane. Both retentate and permeate streams were recycled back to the feed tank. The feed flow rate in the UF experiments was 250 l/h. It implied a cross-flow velocity of 1.7 m/s.

2.5. Resistance in series model

Membrane resistances were measured in order to compare the filterability of the different wastewaters. According to Darcy's law, the total filtration resistance (R_t) in m^{-1} can be calculated with Eq. (1):

$$R_t = \frac{\Delta P}{\mu J_p} \quad (1)$$

where ΔP is the transmembrane pressure (Pa), μ is the viscosity of the permeate (Pa s) and J_p is the permeate flux in $\text{m}^3/(\text{m}^2 \text{ s})$.

The resistance in series model was used to determine quantitatively the degree of the membrane fouling and to study the fouling mechanisms [20,21]. The model states that the total filtration resistance can be calculated as the addition of three resistances; i.e., the intrinsic membrane resistance (R_m), the cake layer resistance (R_c) and the fouling resistance (R_f) Eq. (2). All the resistances are expressed in m^{-1} :

$$R_t = R_m + R_c + R_f \quad (2)$$

R_m , R_c and R_f were determined according to the procedure by Bae and Tak [22]. Thus, distilled water was firstly ultrafiltered for half an hour in order to measure J_w . After that, the membrane was fed with the wastewater sample (BPI or PE samples depending on the test) and consequently J_{ww} was measured. At last, the cake was withdrawn from the membrane surface by rinsing the membrane with distilled water and J_w was measured. Rinsing was carried at a crossflow velocity of 2.5 m/s. Membrane resistances are function of these measured flux values and they were calculated by the Eq. (3–5):

$$R_m = \frac{\Delta P_T}{\mu J_w} \quad (3)$$

$$R_f = \frac{\Delta P_T}{\mu J_w} - R_m \quad (4)$$

$$R_c = \frac{\Delta P_T}{\mu J_{ww}} - R_m - R_f \quad (5)$$

2.6. Statistical study

To the aim of finding a correlation between the different parameters studied, a statistical analysis was carried out by the multiple regression tool of Statgraphics 5.1. P-values lower than 0.05 were considered influential on the analysis.

Two regression analyses were carried out. The first study related the characterization parameters of the BPI samples with their membrane resistances; meanwhile the second one correlated the membrane resistances of the BPI and PE samples.

3. Results

3.1. Pretreatment study

The objective of a pretreatment in a WWTP is removing the particles that could damage the further wastewater treatment processes. In particular, for a MBR, it is tried to minimize the presence of suspended solids, especially hair and fibres. As there is no standard method for the determination of hair and fibres in wastewater, suspended solids are measured to check the efficiency of the sieves [14].

Other important point in the pretreatment is the oil and greases elimination; thereby a stage for their removal should be included in the treatment.

The separations of the suspended solids with the pretreatment of the WWTPs and with the sieving tests performed in the laboratory were compared. Table 2 summarizes these results. Showed values for each

WWTP correspond with the mean values after considering the 5 processed samples. Standard deviations are also included.

It can be highlighted that from the point of view of the SS removal the pretreatments of the WWTPs are equivalent to the laboratory pretreatments with sieves between 500 and 900 μm . This behaviour is very similar in the 4 WWTPs. Lower mesh sizes (150 μm) reduced the SS concentration in wastewater (around 8% for WWTPs 1 and 2, 13.5% for WWTP 3 and 6.5% for WWTP 4, related to the removal efficiencies with 500 μm).

If these results are compared with those reported in the literature, SS removal efficiencies are very similar to those reported [15]. It can be concluded that the pretreatment of the WWTP would be appropriate for a hypothetical further MBR from the point of view of the SS. For this reason and taking into account that the MWWTP pretreatments are equipped with oil and greases separators, BPI samples have been used for the study of the influence of the wastewater composition in the UF.

3.2. Characterization of BPI and PE samples

Table 3 shows the measured values (mean values) for SS, total solids (TS) and oil and greases measured for the BPI samples. In spite of the data variability, it can be stated that in general terms they are in the usual range for municipal wastewater treatment. Only the Sample 2 from WWTP 4 presents SS and oil and greases concentrations too high to be considered a typical value for municipal wastewater. These values can be explained

Table 2

Suspended solids (mg/l) of the PI samples and their values after the filtration with three different sieves in the laboratory and after the MWWTP pretreatment (BPI samples)

	SS (PI)	SS after 900 μm filtration	SS after 500 μm filtration	SS after 150 μm filtration	SS (BPI)
WWTP 1	250.8 \pm 31.5	238.2 \pm 29.0	224.4 \pm 28.6	204.4 \pm 32.6	231.3 \pm 31.4
WWTP 2	253.6 \pm 25.4	239.8 \pm 22.7	233.4 \pm 25.0	211.1 \pm 9.5	231.5 \pm 14.2
WWTP 3	168.8 \pm 10.3	156.8 \pm 8.1	137.7 \pm 4.5	115.5 \pm 12.3	150.0 \pm 11.4
WWTP 4	273.4 \pm 12.6	265.1 \pm 16.9	244.4 \pm 8.4	226.6 \pm 6.0	260.0 \pm 18.2

Table 3

BPI samples characterization

	SS (mg/l)		TS (mg/l)		Oil and greases (mg/l)	
	Sample 1	Sample 2	Sample 1	Sample 2	Sample 1	Sample 2
WWTP 1	288	215	1457	1149	45	40
WWTP 2	200	172	1527	1053	37	27
WWTP 3	120	180	1592	1821	57	22
WWTP 4	140	380	1104	1042	21	53

Table 4
PE samples characterization

	SS (mg/l)		TS (mg/l)	
	Sample 1	Sample 2	Sample 1	Sample 2
WWTP 1	6	5	1423	1141
WWTP 2	5	4	1487	1055
WWTP 3	8	6	1490	1704
WWTP 4	<3	5	1093	1058

by the influence of the recirculation to the equalization tank of sludge liquor and supernatants from the sludge treatment line.

Table 4 shows the mean values obtained for the parameters SS and TS in the PE samples. It can be observed that there are no significant differences in the studied WWTPs.

3.3. Filterability of the pretreated wastewater (BPI samples)

As commented in section 2.5, filterability of wastewater samples was measured in terms of the membrane resistances. Table 5 shows these results.

With regard to R_m , its values should be theoretically equal because they are function of the membrane itself and experiments were carried out with the same membrane type. However, for each test, a membrane of 100 cm² of effective filtration area was cut from a larger sheet. It

Table 5
Membrane resistances (m⁻¹) using the BPI samples as feed in the ultrafiltration

		BPI (Sample 1)	BPI (Sample 2)
WWTP 1	R_m	4.30×10^{11}	4.18×10^{11}
	R_f	1.12×10^{12}	9.02×10^{11}
	R_c	1.76×10^{12}	1.06×10^{12}
	R_t	3.31×10^{12}	2.38×10^{12}
WWTP 2	R_m	4.02×10^{11}	5.88×10^{11}
	R_f	3.18×10^{11}	2.82×10^{11}
	R_c	1.63×10^{12}	1.66×10^{12}
	R_t	2.35×10^{12}	2.53×10^{12}
WWTP 3	R_m	5.85×10^{11}	4.05×10^{11}
	R_f	5.16×10^{11}	5.35×10^{11}
	R_c	1.18×10^{11}	1.41×10^{12}
	R_t	2.28×10^{12}	2.35×10^{12}
WWTP 4	R_m	4.64×10^{11}	4.35×10^{11}
	R_f	6.36×10^{11}	8.65×10^{11}
	R_c	1.51×10^{12}	2.08×10^{12}
	R_t	2.61×10^{12}	3.38×10^{12}

was observed that the characteristics of the membrane were not completely uniform on the total surface.

Total resistances were similar for the 4 wastewaters tested (10^{12} m⁻¹ order of magnitude). This result is due to the fact that the four wastewaters are predominantly of urban origin. In addition, R_c values were always higher than R_f values. It means that the main membrane resistance is the cake layer resistance.

If the characterization parameters (SS, TS and oil and greases) and membrane resistances are related, it can be stated that the parameter which had higher influence on the values of the membrane resistances was the SS concentration. The Eq. (6) and (7) represent the statistical analysis; they describe the multiple regression models after rejecting non influential variables (TS and oil and greases).

$$R_c = 8.7506 \times 10^9 + 3.1012 \times 10^7 SS \quad (6)$$

$$R_t = 1.69744 \times 10^{10} + 4.59939 \times 10^7 SS \quad (7)$$

Specifically, suspended solids presented a p-value <0.05 in R_c , and p-value <0.01 in R_t resistance. Thus, the SS concentration was the most influential parameter to take into account when R_c and R_t are analysed.

3.4. Relation between filterability values of the samples before and after the biological processes (BPI and PE samples)

Through this section possible correlations between PE and BPI membrane resistances values were studied. Figs. (2–5) show the values of the different membrane resistances for the samples before and after the biological treatment in the four WWTPs. For each WWTP, R_m , R_f , R_c and R_t of PE and BPI samples can be compared. The values calculated for the same type of membrane resistance have been plotted next to each other.

For all the WWTPs R_t is significantly lower for the PE than for the BPI samples as expected. If all the results are considered, the mean value for the R_t reduction after biological treatment is 1.50×10^{12} m⁻¹ with a standard deviation of 5.67×10^{11} m⁻¹. R_t values for PE samples were very similar, ranging between 9.53×10^{11} (WWTP 1, Sample 1) and 1.45×10^{12} (WWTP 3, Sample 1).

The same tendency followed R_c . As proved in Section 3.2, SS is the main parameter influencing the cake resistance. In this way, the lower R_c values in the PE samples are associated with the low SS concentrations (lower than 10 mg/l for all the PE samples).

On the contrary, the behaviour of the R_f values varied depending on the sample considered. In this way, for WWTPs 1 and 4 R_f values were considerably lower for PE samples. However, for WWTPs 2 and 3, there were hardly any differences in the measured R_f values before

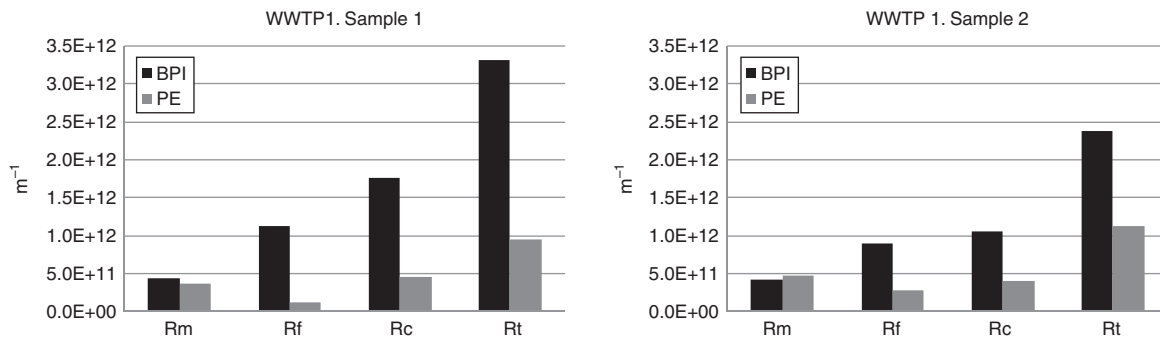

Fig. 2. Comparison between the membrane resistances for the BPI and PE samples from WWTP 1.

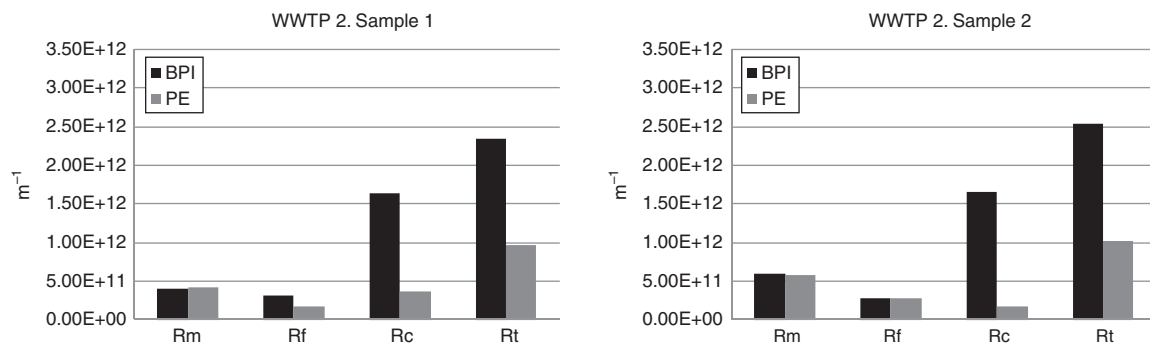

Fig. 3. Comparison between the membrane resistances for the BPI and PE samples from WWTP 2.

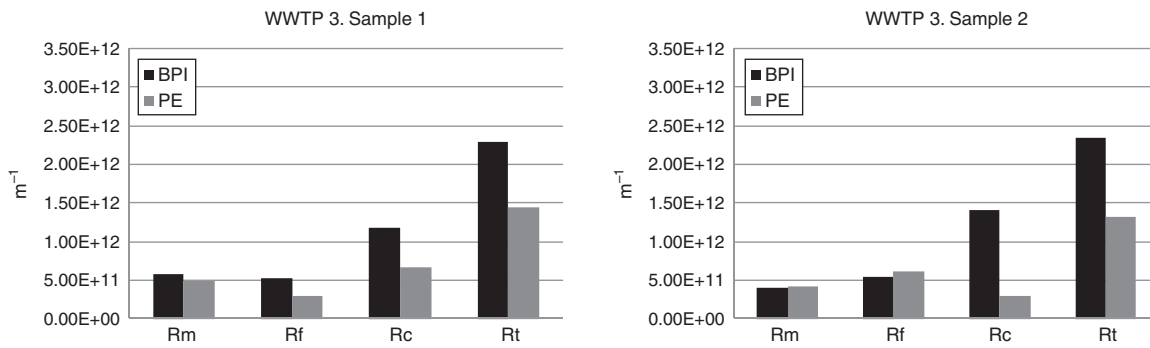

Fig. 4. Comparison between the membrane resistances for the BPI and PE samples from WWTP 3.

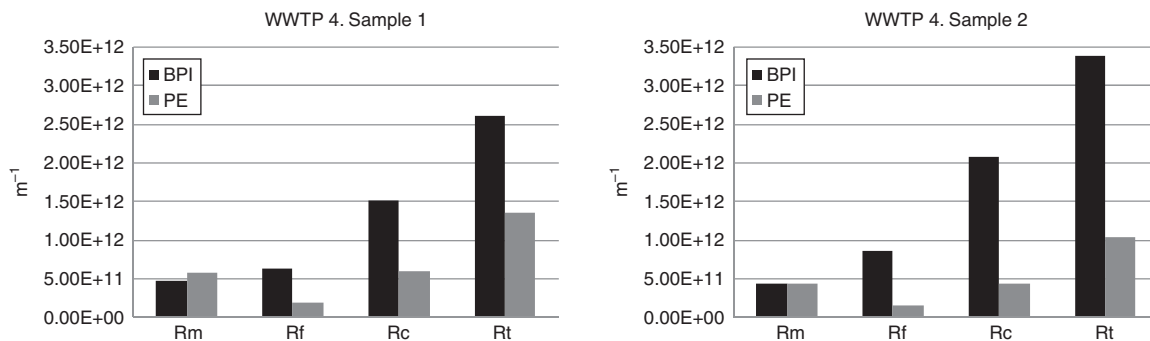

Fig. 5. Comparison between the membrane resistances for the BPI and PE samples from WWTP 4.

and after the biological treatment. For the Sample 2 from WWTP 3, the R_f value was even higher for the PE sample than that measured for the BPI sample. In addition, in absolute terms the two highest values of R_f measured were obtained from the samples of WWTP 3.

On the other side, taking into account that statistical significance was assumed at $P < 0.05$, the regression analysis showed that no significance correlation was found among the membrane resistances before and after the biological treatment. In fact, R_f values in BPI samples have to be influenced by the dissolved organic matter in wastewater, whereas R_f values in PE samples will be influenced by the soluble microbial products released by the microorganisms in the activated sludge reactor that are not separated in the secondary settler. In other words, the biological treatment eliminates a considerable part of the fouling membrane resistance of the BPI samples but generates microbial products that contribute to it in high extent.

In view of implementing a MBR system, comparisons between the fouling membrane resistances of wastewater before and after the biological treatment may be important to predict the eventual influence of the wastewater characteristics on the membrane fouling. High fouling membrane resistances by filtering treated wastewater (WWTP 3) may indicate the presence in the wastewater of non biodegradable substances that remain after the activated sludge process. They would contribute to the membrane fouling if a MBR was operated. It is clear that this relation can only be established when the biological process works correctly and there are not anomalous concentrations of soluble microbial products in the effluent, which would justify the high membrane resistance values independently of the raw wastewater characteristics.

4. Conclusions

Membrane fouling in a MBR is influenced by wastewater characteristics. Wastewater pretreatment is of paramount importance in order to separate oil and greases, hairs and other suspended solids. After evaluating the pretreatments of four MWWTPs and the characteristics of the wastewater, it can be highlighted that from the point of view of the SS removal, the pretreatments of the studied WWTPs were equivalent to the laboratory pretreatments with sieves between 500 and 900 μm . For 500 μm , SS removal efficiencies between 6.5 and 13.5% were achieved.

The membrane resistances tests to evaluate the filterability of the BPI samples showed that the only parameter that statistically influenced on the membrane resistances was the SS concentration. In particular, a relation between SS and the total resistance and between SS and the cake resistance were estimated.

The total membrane resistances for the PE samples were considerably lower than those measured with BPI samples. This difference is due to the considerable cake resistance diminution after the biological process. However, different results were obtained if fouling resistances are compared. In two of the four MWWTPs, no significant decrease of the fouling resistance was observed for the wastewater after the biological process. The comparison of the fouling membrane resistances of a wastewater before and after the biological treatment could give valuable information about the presence of dissolved substances in the wastewater that could contribute to the membrane fouling.

References

- [1] T. Stephenson, K. Brindley, S. Judd and B. Jefferson (2000), *Membrane bioreactors for wastewater treatment*, 1st ed., IWA publishing, London, Great Britain.
- [2] S. Judd, *The MBR Book*, 1st ed., Elsevier, Amsterdam, 2006.
- [3] G. Laera, A. Pollice, D. Saturno, C. Giordano and R. Sandulli, Influence of sludge retention time on biomass characteristics and cleaning requirements in a membrane bioreactor for municipal wastewater treatment, *Desalination*, 236 (2009) 104–110.
- [4] P. Le-Clech, V. Chen and T.A.G. Fane, Fouling in membrane bioreactors used in wastewater treatment, *J. Membr. Sci.*, 284 (2006) 17–53.
- [5] G. Di Bella, F. Durante, M. Torregrossa, G. Viviani, P. Mercurio and A. Cicala, The role of fouling mechanisms in a membrane bioreactor, *Water Sci. Technol.*, 55(8–9) (2007) 455–464.
- [6] A. Drews, H. Arellano-Garcia, J. Schöneberger, J. Schaller, G. Wozny and M. Kraume, Model-based recognition of fouling mechanisms in membrane bioreactors, *Desalination*, 236 (2009) 224–233.
- [7] A. Drews, Membrane Fouling in Membrane Bioreactors—Characterisation, Contradictions, Cause and Cures, *J. Membr. Sci.*, 363(1–2) (2010) 1–28.
- [8] S. Lyko, T. Wintgens, D. Al-Halbouni, S. Baumgarten, D. Tacke, K. Drensla, A. Janot, W. Dott, J. Pinnekamp and T. Melin, Long-term monitoring of a full-scale municipal membrane bioreactor—Characterisation of foulants and operational performance, *J. Membr. Sci.*, 317 (2008) 78–87.
- [9] W. Khongnakorn, C. Wisniewski, L. Pottier and L. Vachoud, Physical properties of activated sludge in a submerged membrane bioreactor and relation with membrane fouling, *Sep. Purif. Technol.*, 55 (2007) 125–131.
- [10] S. Rosemberg and M. Kraume, Filterability of activated sludge in membrane bioreactors, *Desalination*, 146 (2002) 373–379.
- [11] W. Lee, S. Kang and H. Shin, Sludge characteristics and their contribution to microfiltration in submerged membrane bioreactors, *J. Membr. Sci.*, 216 (2003) 217–227.
- [12] P. Grelier, S. Rosenberg and A. Tazi-Pain, Influence of sludge retention time on membrane bioreactor hydraulic performance, *Desalination*, 192 (2006) 10–17.
- [13] D.Y. Imer-Koseoglu, A. Karagunduz and B. Keskinler, Fouling characteristics of microfiltration membranes during the filtration of jet loop membrane bioreactor (JLMBR) activated sludge, *Desalin. Water Treat.*, 26(1–3) 124–130.
- [14] F.B. Frechen, W. Schier and C. Linden, Mechanische Abwassertorbereitung auf kommunalen Membranbelebungsanlagen, *Korrespondenz Abwasser*, 55(1) (2008) 39–44.
- [15] F.B. Frechen, W. Schier and C. Linden, Pre-treatment of MBR application, *Desalination*, 231 (2008) 108–114.
- [16] W. Schier, F.B. Frechen and S. Fischer, Efficiency of mechanical pre-treatment on European MBR plants, *Desalination*, 236 (2009) 85–93.

- [17] H.F. Van der Roest, D.P. Lawrence and A.G.N. Van Bentem, *Membrane bioreactors for municipal wastewater treatment*, 1st ed., IWA Publishing, London, 2002.
- [18] B. Rusten and H. Odegaard, Evaluation and testing of fine mesh sieve technologies for primary treatment of municipal wastewater, *Water Sci. Technol.*, 54(10) (2006) 31–38.
- [19] APHA, *Standard methods for the examination of water and wastewater*, 21th ed., Washington, 2005.
- [20] M. Mulder, *Basic principles of membrane technology*, 1st Ed., Kluwer academic Publishers, The Netherlands, 1991.
- [21] H. Choi, K. Zhang, D.D. Dionysiou, D.B. Oerther and G.A. Sorial, Influence of cross-flow velocity on membrane performance during filtration of biological suspension, *J. Membr. Sci.*, 248 (2005) 189–199.
- [22] T.H. Bae and T.M. Tak, Interpretation of fouling characteristics of ultrafiltration membranes during the filtration of membrane bioreactor mixed liquor, *J. Membr. Sci.*, 264 (2005) 151–160.